

Coolspool Hybrid 300

28V DIESEL-BATTERY COMBINATION GPU

Powered by a 3-cylinder, water-cooled Kubota diesel engine, fully Tier IV compliant, the Coolspool Hybrid 300 is designed to provide continuous power for avionics and to start the engines on all DC turbine and turboprop aircraft.

Coolspool users benefit from a compact unit, user friendly controls and very low operating costs, with the further advantage of low dBA signature and reduced CO₂ emissions. Normally, a diesel GPU four times the size of the Coolspool Hybrid 300 is necessary to deliver the peak amperage for starting large turbines.

The Coolspool Hybrid 300 achieves the same starting performance using a 900cc (55 cu In) Kubota diesel engine coupled to a powerful generator powering 3 x 100amp 28V DC power supplies. These operate in parallel with a bank of high discharge batteries that provide instant ripple free power for turbine starting and aircraft loads exceeding 300 amps.

The Coolspool Hybrid 300 is suitable for all types of operation, including offshore helicopter operations, FBO and maintenance organisations and daily regional airline use. Where multiple departures of large regional aircraft – such as the Q400 or ATR – are scheduled, the Coolspool Hybrid 300 can be fitted with Powervamp's 'PBS' (Power Boost System). The PBS sustains voltage during the critical initial start sequence on large turboprop aircraft with shaft or free turbine engines, thereby ensuring a fast, cool start while maximising battery life.

No other GPU delivers the versatility and convenience of Powervamp's Coolspool Hybrid 300. This compact and efficient diesel GPU also provides single phase AC output to enable ground staff to operate vacuum cleaners or other equipment during night servicing.

In a hangar or confined space, the Coolspool Hybrid 300 engine can be shut down. A selector switch isolates the generator and allows external 3-phase AC power to be connected from a suitable utility supply. The full output from the Coolspool Hybrid 300 is then available with the external power source constantly maintaining the batteries in a full state of charge.



Available in various configurations and in series production over 17 years, with sales to several armed forces, the Coolspool Hybrid 300 is the civil version of Powervamp's DC GPU. It is designed for operators requiring versatile, standalone, high output DC power at a fraction of the cost of a conventional diesel GPU.

Supplied as standard with



4m x 70mm² hard-wired Nato lead



Spare wheel



Wheel brake system

Coolspool Hybrid 300 is designed to start the turbines on all DC aircraft. Typical power plant includes:*

DC regional jets and turboprop airline operations using PT6C-67, TPE 331-12, RR Dart 356, RR AE3007A, PW121, PW127, PW150A, ALF 502, CF34B, BR710, or power plants of a similar specification and those of all DC helicopters.



All regular line ops, 30-80 seat airline DC turboprops, Mil transports. Regional airports, FBOs, pre-flight and start

Coolspool Hybrid 300



Features

- Industrial Kubota diesel engine
 - 3-cylinder water-cooled
 - Tier IV emissions compliant for use worldwide
 - Worldwide support network
 - Low fuel consumption
 - Quiet operation
 - Diesel or Jet A1/JP8**
- Large fuel tank: 14 hours run time at 50% load
- Super-smooth, low ripple 28V DC output for sensitive avionics
- 300 amp continuous output from 3 x 100 amp paralleled modules provided redundant performance and guarantees full battery output for turbine starts
- Single phase 16 amp 115 VAC or 230 VAC output for plug-in accessories++
- Designed for hangar use. Connects to suitable 3-phase utility supply with diesel shutdown
- Comprehensive, easy-to-use, intelligent digital control panel
- Digital control system delivers maximum aircraft protection
- Maintenance free ultra high power sealed lead acid batteries deliver multi turbine starts
- Output lead 4, 6 or 8 metres. Section 120mm² fitted with heavy duty rubber nato plug
- Anti-collision beacon

** Note: If using Jet A1, JP8 or similar, some loss of power will occur compared to diesel due to jet fuel's lower calorific value.

++ Input lead required

- HEAVY DUTY CHASSIS with quick detachable panels includes the following features:
 - Hot dipped galvanised chassis with fork pockets and tie-down points
 - Powder-coated alloy body panels with top mounted cable compartment
 - Compact design, side protection bars, rear bumper, tow bar with handle and eye
 - Rear wheel maintenance free torsion suspension for uneven ground operations
 - Tubeless pneumatic tyres as standard
 - Tow bar activated front brake with foot operated release
- Civil or military use
- Complies with ISO 6858
- Cleared for air transportation when drained of fluids
- The PBS (Power Boost System) is a regenerative power source that maintains the voltage during the initial start sequence:
 - It delivers faster, cooler starts
 - It has extremely low internal impedance
 - It is maintenance free throughout its life
 - Has a design life of over 1,000,000 cycles
 - Helps extend battery life

Control panel

LCD screen

A large blue-backlit LCD screen provides detailed information and allows interrogation of the hybrid 300's systems. Real time updates inform the operator on the following information:

- Engine speed
- Engine run time
- Fuel level
- Engine battery voltage
- Batteries state of charge
- DC output voltage and current
- DC batteries charging voltage and current
- AC generator voltage and frequency
- AC mains input voltage and frequency
- AC output voltage and frequency

Instant status indication

High Intensity LED status indicators provide instant status overview: GREEN: System Healthy; AMBER: System in Alarm; RED: System Fault

Menu function

Simple menu navigation allows easy access to additional features and settings.

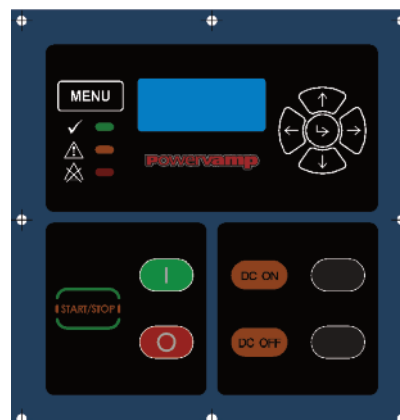

Coolspool Hybrid 300



Coolspool Hybrid 300: starting both turbines on the Agusta Westland AW139

System configuration options:

Depending upon the specific needs of the operator, the Coolspool Hybrid 300 can be configured to increase the capacity of the battery bank or adjust the output voltage and power delivery performance (PBS system).

Coolspool Hybrid 300 Configuration Options

CSH300 – EC1 – 4B – 50 – IC5M – 6M

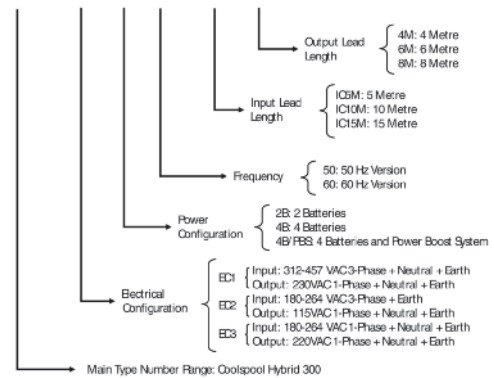

All weather controls

Large rubber ON/OFF buttons offer easy robust control of the system in all weather conditions.



Protections

The Coolspool Hybrid 300's electronic systems incorporate multi-level protection guaranteeing spike and ripple free power delivery with total voltage stability thereby protecting the aircraft from transients or over/under voltage situations, even during abnormal conditions. These protections are backed by software that monitors:

- Reverse polarity
- Reverse current
- Fail to start
- Low oil pressure
- Engine high temperature
- Engine under/over speed
- Generator under/over frequency
- Generator under/over voltage
- Engine battery charge failure
- Low fuel level
- Power supply failure
- Output under/over voltage

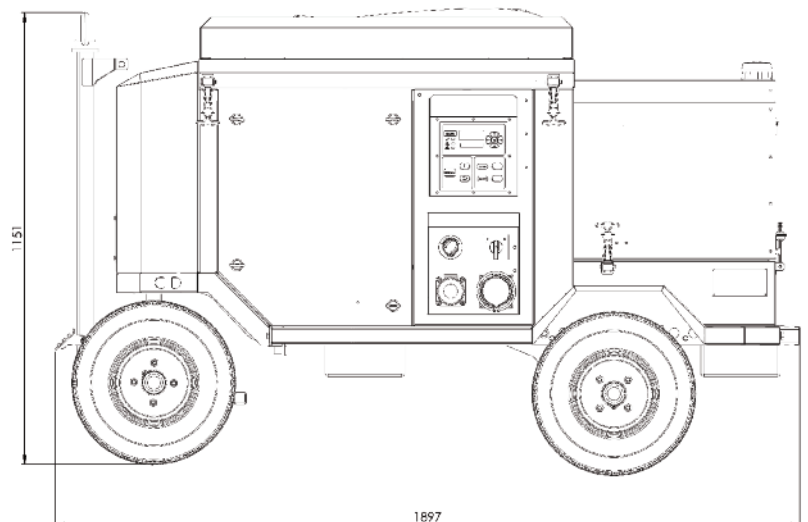
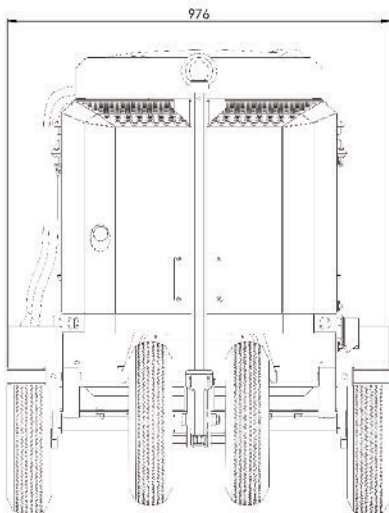

Coolspool Hybrid 300

Specifications

Power configuration	2 x Batteries	4 x Batteries	4 x Batteries and PBS
Peak amps***	5,000	10,000	17,600
Nominal voltage	Batteries 24V DC/Power supplies 28V DC		
Standing voltage	25.6V DC		
Amp/hour capacity	114 Ah @ 10 hr rate (20°C)	228 Ah @ 10 hr rate (20°C)	Batteries: 228 Ah @ 10 hr rate (20°C) & 2 x PBS
Standing voltage	25.6V DC		
Amp/hour capacity	114 or 228 Ah @ 10 hr rate (20°C) (depending on model)		
Operating temp	-30°C to +50°C (-22°F to 122°F)		
Case	Hot dip galvanised steel frame with alloy panels, powder-coat paint		
Control panel	LCD screen provides detailed information. Large rubber ON/OFF buttons for easy operation		
Aircraft cable	Options: 4m (13ft), 6m (20ft) or 8m (26ft) with heavy-duty rubber Nato connector		
Output current	300A continuous (with internal power supplies)		
Input voltage (for hangar operation)	Option 1 (EC1): 312-457 VAC / 47-63Hz 3-phase neutral + earth Option 2 (EC2): 180-264 VAC / 47-63Hz 3-phase + earth Option 3 (EC3): 180-264 VAC / 47-63Hz 1-phase + neutral + earth (only in mains mode with the engine turned off)		
Input current (for hangar operation)	Option 1 (EC1): 18A @ 400V AC / 3-phase (typical) Option 2 (EC2): 35A @ 200V AC / 3-phase (typical) Option 3 (EC3): 64A @ 200V AC / 1-phase (typical) (only in mains mode with the engine turned off)		
Cooling	Forced ventilation		
Forklift points	2 x forklifting points on both sides		
Engine	Kubota 3-cylinder		
Emission regulation	EPA Tier 4		
Fuel type	Diesel / Jet A1 / JP8†		
Fuel tank capacity	33 litres (7 gallons)		
Noise level	74 dB(A) @ 7 metre		
Aux output	Option 1 (EC1): 230 VAC 50Hz	Option 2 (EC2): 115 VAC 60Hz	Option 3 (EC3): 115 VAC 60Hz
Dimensions	L 1900mm (75in) W 970mm (38in) H 1130mm (45in)		
Weight	488kg (1076lbs) for a dry unit with 4m output lead	568kg (1252lbs)	583kg (1285lbs)
Input lead (for hangar operations)	Options: 5m (16ft), 10m (33ft) or 10m (49ft)		
Maintenance	Free		
NGAGE	KD628		

***The quoted figures are the theoretical instant short circuit current across the battery terminals. The maximum amperage that will be delivered by the GPU to the aircraft's external power connection is significantly reduced due to cable length, cable size and duration of power. These figures are quoted for comparison purposes only

† If using Jet A1, JP8 or similar, some loss of power will occur compared to diesel due to jet fuel's lower calorific value.

Other GPUs and power supplies in the Powervamp range



PS300



Coolspool 260



Coolspool 410



TRU 2400-2

Powervamp
ADVANCED POWER SOLUTIONS

Powervamp Ltd 22 Bridgwater Court, Oldmixon Crescent, Weston-super-Mare, BS24 9AY, England

Tel: +44 (0)1934 643000 Fax: +44 (0)1934 642800 Email: info@powervamp.com www.powervamp.com



© Powervamp Ltd. Measurements, weights, technical performance and other specification data are typical and may vary. Powervamp reserves the right to alter or amend specifications without notice as part of its program of continuous improvement. Powervamp is a trademark of Powervamp Ltd.

